

VOLVO PENTA INDUSTRIAL DIESEL

TAD940GE

265 kW (355 bhp) at 1500 rpm, 273 kW (366 bhp) at 1800 rpm, acc. to ISO 3046

The TAD940GE is a powerful, reliable and economical Generating Set Diesel Engine built on the dependable Volvo in-line six design.

Durability & low noise

Designed for the easiest, fastest and most economical installation. Well balanced to produce smooth and vibration-free operation with low noise level, featured with high torque.

To maintain a controlled working temperature in cylinders and combustion chambers, the engine is equipped with piston cooling. The engine is also fitted with replaceable cylinder liners and valve seats / guides to ensure maximum durability and service life of the engine.

Operational economy and Low exhaust emission

The state of the art, high-tech injection and air charging system with low internal losses contributes to excellent combustion and low fuel consumption.

The TAD940GE complies with EU-stage 2 and TA-luft exhaust emission regulations.

Easy service & maintenance

Easily accessible service and maintenance points contribute to the ease of service of the engine.

Technical description

Engine and block

- Optimized cast iron cylinder block with optimum distribution of forces without the block being unnecessary heavy.
- Wet, replaceable cylinder liners
- Piston cooling for low thermal load on pistons and reduced ring temperature
- Tapered connecting rods to reduce risk of piston cracking
- Crankshaft induction hardened bearing surfaces and fillets with seven main bearings for moderate load on main and big-end bearings
- Nitrocarburized transmission gears for heavy duty operation
- Keystone top compression rings for long service life
- Viscous type crankshaft vibration damper
- Replaceable valve guides and valve seats
- Over head camshaft and four valves per cylinder equipped with camshaft damper to reduce noise and vibrations.

Lubrication system

- Full flow oil cooler
- Full flow disposable spin-on oil filters, for extra high filtration
- The lubricating oil level can be measured during operation (Standard dipstick only)
- Gear type lubricating oil pump, gear driven by the transmission

Fuel system

- Non-return fuel valve
- Electronic Unit Injectors
- Fuel pre-filter with water separator and water-in-fuel indicator / alarm
- Gear driven low-pressure fuel pump
- Fuel pressure switch
- Self de-aerating system. When replacing filters all fuel stays in the engine.

Turbo charger

- Efficient and reliable turbo charger
- Extra oil filter for the turbo charger

Cooling system

- Air to air intercooler
- Belt driven, maintenance-free coolant pump with high degree of efficiency
- Coolant filter as standard
- Fan hub

- Fan & belt guard
- Efficient cooling with accurate coolant control through a water distribution duct in the cylinder block. Reliable sleeve thermostat with minimum pressure drop
- Tropical radiator
- Radiator guard
- Pusher type fan

Electrical system

- Engine Management System 2 (EMS 2), an electronically controlled processing system which optimizes engine performance. It also includes advanced facilities for diagnostics and fault tracing
- The instruments and controls connects to the engine via the CAN SAE J1939 interface and the Control Interface Unit (CIU). The CIU converts the digital CAN bus signal to an analog signal, making it possible to connect a variety of instruments.
- Sensors for oil pressure, oil temp, boost pressure, boost temp, coolant temp, fuel temp, water in fuel, fuel pressure and two speed sensors. Crank case pressure, oil level and air filter pressure droop sensors
- Alternator 24V / 80A



**VOLVO
PENTA**

TAD940GE

Technical Data

General

Engine designation	TAD940GE	
No. of cylinders and configuration	in-line 6	
Method of operation	4-stroke	
Bore, mm (in.)	120 (4.72)	
Stroke, mm (in.)	138 (5.43)	
Displacement, l (in ³)	9.36 (571)	
Compression ratio	20.2:1	
Dry weight, kg (lb)	1015 (2238)	
Dry weight with Gen Pac, kg (lb)	1354 (2986)	
Wet weight, kg (lb)	1065 (2348)	
Wet weight with Gen Pac, kg (lb)	1404 (3096)	

Performance	1500 rpm	1800 rpm
with fan, kW (bhp) at:		
Prime Power	240 (322)	246 (330)
Max Standby Power	265 (355)	273 (366)

Lubrication system	1500 rpm	1800 rpm
Oil consumption, l/h (US gal/h) at:		
Prime Power	0.05 (0.012)	0.05 (0.013)
Max Standby Power	0.05 (0.013)	0.05 (0.014)
Oil system capacity incl filters, liter (US gal)	33 (8.7)	

Fuel system	1500 rpm	1800 rpm
Specific fuel consumption at:		
Prime Power, g/kWh (lb/hph)		
25%	230 (0.373)	242 (0.392)
50%	206 (0.334)	214 (0.347)
75%	197 (0.319)	203 (0.329)
100%	201 (0.326)	205 (0.332)
Max Standby Power, g/kWh (lb/hph)		
25%	227 (0.368)	239 (0.388)
50%	203 (0.329)	210 (0.341)
75%	197 (0.319)	202 (0.328)
100%	204 (0.330)	204 (0.330)

Intake and exhaust system	1500 rpm	1800 rpm
Air consumption, m ³ /min (cfm) at:		
Prime Power	18.1 (638)	21.7 (765)
Max Standby Power	20.0 (705)	23.2 (820)
Max allowable air intake restriction, kPa (In wc):	5 (20.1)	5 (20.1)
Heat rejection to exhaust, kW (BTU/min)	216 (12284)	223 (12682)
Exhaust gas temperature after turbine, °C (°F)	488 (910)	429 (804)
Max allowable back-pressure in exhaust line, kPa (In wc)	10.0 (40.2)	10.0 (40.2)
Exhaust gas flow, m ³ /min (cfm)	49.6 (1750)	

Standard Equipment

	Engine	Gen Pac
Engine		
Automatic belt tensioner	•	•
Lift eyelets	•	•
Flywheel housing with conn. acc. to SAE 1	•	•
Flywheel for 14" flex. plate and flexible coupling	•	•
Vibration dampers	•	•
Engine suspension		
Fixed front and rear suspension	•	•
Lubrication system		
Oil dipstick	•	•
Full-flow oil filter of spin-on type	•	•
By-pass oil filter of spin-on type	•	•
Oil cooler, side mounted	•	•
Low noise oil sump	•	•
Fuel system		
Fuel filters of disposable type	•	•
Electronic unit injectors	•	•
Pre-filter with water separator and water-in-fuel indicator/alarm	•	•
Intake and exhaust system		
Air filter without rain cover	•	•
Air filter with replaceable paper insert	•	•
Air restriction indicator	•	•
Air cooled exhaust manifold	•	•
Connecting flange for exhaust pipe	•	•
Exhaust flange with v-clamp	•	•
Turbo charger, high right side	•	•
Cooling system		
Tropical radiator incl intercooler	–	•
Belt driven coolant pump	•	•
Fan hub	–	•
Thrust fan	–	•
Fan guard	–	•
Belt guard	–	•
Control system		
Engine Management System 2 (EMS 2) with CAN-bus interface SAE J1939	•	•
Alternator		
Alternator 80A / 24V	•	•
Starting system		
Starter motor, 5.5kW, 24V	•	•
Connection facility for extra starter motor	•	•
Instruments and senders		
Temp. and oil pressure for automatic stop/alarm	•	•
Engine Packing		
Plastic wrapping	•	•

– optional equipment or not applicable

• included in standard specification

Dimensions TAD940GE

Not for installation

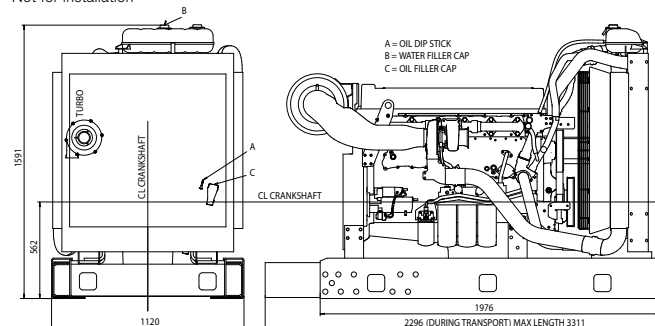

Note! Not all models, standard equipment and accessories are available in all countries. All specifications are subject to change without notice.

The engine illustrated may not be entirely identical to production standard engines.

Power Standards

The engine performance corresponds to ISO 3046, BS 5514 and DIN 6271. The technical data applies to an engine without cooling fan and operating on a fuel with calorific value of 42.7 MJ/kg (18360 BTU/lb) and a density of 0.84 kg/litre (7.01 lb/US gal, 8.42 lb/Imp gal), also where this involves a deviation from the standards.

Exhaust emissions

The engine complies with EU stage 2 emission legislation according to the Non Road Directive EU 97/68/EEC. The engine also complies with TA-luft exhaust emission regulations.

Rating Guidelines

PRIME POWER rating corresponds to ISO Standard Power for continuous operation. It is applicable for supplying electrical power at variable load for an unlimited number of hours instead of commercially purchased power. A10 % overload capability for governing purpose is available for this rating.

MAXIMUM STANDBY POWER rating corresponds to ISO Standard Fuel Stop Power. It is applicable for supplying standby electrical power at variable load in areas with well established electrical networks in the event of normal utility power failure. No overload capability is available for this rating.

1 bhp = 1 kW x 1.341

VOLVO PENTA

AB Volvo Penta
SE-405 08 Göteborg, Sweden
www.volvopenta.com