



TBD 616. Der Gen Motor.



384 - 1223 kVA at 1500/1800 min⁻¹



These are the characteristics of the 616:

- Modern 8-, 12- and 16-cylinder 60°V-engines.
- Turbocharging with charge air cooling.
- Crankshaft with bolted counterweights (8-cylinder engine).
- Electronic governor included in standard scope of supply.
- Four-valve technology with high-pressure injection and centrally arranged injection nozzle.
- Powerful engine with high-power-to-volume ratio.
- Compact design.
- Proven engine technology.

Your benefits:

- ▶ Low noise level reduces costs for noise attenuation measures.
- ▶ Compact design cuts down installation space requirement and thus production costs.
- ▶ Strong component reinforcement decreases wear and thus spare parts requirement. High operating reliability and long life.
- ▶ Low exhaust emissions for a cleaner environment. The stringent exhaust regulations of TA-Luft 2000 (German Clean Air Act) are easily fulfilled.
- ▶ Operating cost savings through fuel-optimized engines meeting TA-Luft 4000.

► Technical data

Engine type		TBD 616 V8		TBD 616 V12		TBD 616 V16	
Speed	min ⁻¹	1500	1800	1500	1800	1500	1800
Frequency	Hz	50	60	50	60	50	60

Engine/genset ratings ¹⁾							
Continuous power, ICN (COP) ²⁾	kW	384	432	576	648	768	864
Prime power, ICN (PRP) ³⁾	kW	441	476	662	714	882	950
Limited-time running power, IFN (LTP) ⁴⁾	kW	463	515	695	772	926	1030
Typical generator power output (COP) ⁵⁾	kVA	451	508	680	765	912	1026
Typical generator power output (PRP) ⁵⁾	kVA	518	559	782	843	1047	1128
Typical generator power output (LTP) ⁵⁾	kVA	544	605	821	912	1100	1223

Basic engine data							
Inertia moment J							
- Engine without flywheel	kg/m ²	1.81	1.81	2.91	2.91	3.56	3.56
- Flywheel	kg/m ²	5.66	5.66	5.66	5.66	5.66	5.66
Weight, engine w/o cooling system	kg	1550	1550	2300	2300	2600	2600

Governor							
Governor electronic		Woodward	Gendec	Woodward	Gendec	Woodward	Gendec
- Speed droop (static, option)	%	0	0	0	0	0	0
Control quality ⁶⁾		G2	G2	G2	G2	G2	G2

Load acceptance							
Recovery time							
at 80 % continuous power (COP)	sec.	3.0	-	2.5	-	2.0	-
at 100 % continuous power (COP)	sec.	3.0	-	2.5	-	2.0	-

Fuel system							
Specific fuel consumption at COP ⁷⁾							
100 % load	g/kWh	192	194	191	193	198	199
75 % load	g/kWh	192	194	191	193	198	198
50 % load	g/kWh	197	202	196	201	203	204

Cooling system/cooling capacity							
Coolant volume engine	l	60	60	80	80	110	110
Cooling air flow rate	WL-LLK*	m ³ /s	11.76	-	15.36	-	19.44
	LL-LLK**	m ³ /s	7.26	-	8.64	-	13.50
Heat in coolant	WL-LLK	kW	150.9	166.5	222.6	245.8	257.4
	LL-LLK	kW	148.9	165.3	219.6	243.8	254.0
Heat in charge air cooler	WL-LLK	kW	60.9	79.2	90.4	117.9	126.6
	LL-LLK	kW	62.2	80.9	92.4	120.3	129.3
Min. coolant flow rate required for (Δt 10 K)	WL-LLK	m ³ /h	10.42	13.56	19.85	21.92	22.96
	LL-LLK	m ³ /h	13.28	14.74	19.58	21.75	22.66
Perm. resistance at Δt 10 K	WL-LLK	mbar	1305	1835	1266	1787	1247
	LL-LLK	mbar	1308	1837	1271	1791	1254
Max. permissible air flow resistance	mbar	2.6	2.6	2.6	2.6	2.6	2.6
Max. coolant temperature at engine outlet (alarm)	°C	95	95	95	95	95	95
Heat radiation	WL-LLK	kW	32.3	36.7	48.2	54.8	66.6
	LL-LLK	kW	32.1	36.5	48.0	54.5	66.3

► Technical data

Engine type		TBD 616 V8		TBD 616 V12		TBD 616 V16	
Speed	min ⁻¹	1500	1800	1500	1800	1500	1800
Frequency	Hz	50	60	50	60	50	60
Lubrication system							
Lube oil consumption at full load		max. 0.5%		max. 0.5%		max. 0.5%	
Lube oil specification		min. API-CD and CC MC D4/ D5					
Lube oil volume, oil pan	l	43	43	64	64	85	85
Oil temperature max.	°C	120	120	120	120	120	120
Full-flow filter		Single filter		Single filter		Single filter	
Min. oil pressure (shutdown)	bar	1.2	1.2	1.2	1.2	1.2	1.2
Combustion air system							
Combustion air volume flow (COP)	m ³ /h	1767	2192	2640	3277	3623	4369
Max. intake vacuum (filter clean)	mbar	30	30	30	30	30	30
Exhaust system							
Exhaust mass flow rate at full load (COP)	kg/h	2057	2552	3074	3815	4228	5122
Exhaust gas mass flow at full load and 25°C ambient temperature	°C	470	431	469	430	524	463
Max. permissible exhaust backpressure	mbar	35	35	35	35	35	35
Exhaust flange	mm	2xDN100	2xDN100	2xDN100	2xDN125	2xDN125	2xDN125
TA-Luft (4000)	mg/nm ³	yes	yes	yes	yes	yes	yes
Engine electrics							
Electrical equipment:							
- Starter	kW	6.6	6.6	6.6	6.6	6.6	6.6
- Alternator	A/V	55/28	55/28	55/28	55/28	55/28	55/28
- Battery (min. capacity)	Ah	2x160	2x160	2x192	2x192	2x224	2x224
- Coolant preheating unit	W	2000W/230V/50 Hz		2000W/230V/50 Hz		2000W/230V/50 Hz	
- Voltage	V	24	24	24	24	24	24
Cold-start capability							
cold-start limit temperature							
- with starting aid	°C	-30	-30	-30	-30	-30	-30
- without starting aid	°C	-15	-15	-15	-15	-15	-15
Noise emission⁹⁾							
Sound power level	dB(A)/1pW	115.2	116.2	115.6	118.6	119	121
Sound pressure level at full load, 1m distance	dB(A)	105	106	106	107	107	108

- 1) Power reduction caused by altitude and temperature without deduction of fan power consumption. For details refer to DEUTZ.
- 2) Net continuous power 100% available at flywheel, no time limitation, plus 10% extra power for governing purposes.
- 3) Prime power 100%, average power output 80% within 24 hours, plus 5% extra power for governing purposes.
- 4) Limited-time running power 100% which must be available 500 hours/year (thereof max. 300 hours/year continuously), no overload permissible; the required extra power for governing purposes must be taken into account however.
- 5) Taking into account typical generator efficiency, power factor $\cos(\varphi) = 0.8$. Generator efficiency: 0.95.
- 6) Performance acc. to ISO 8528.
- 7) For fuel specification see operation manual.
- 8) Without cooling system.

*) WL-LLK = water-to-air charge air cooler

**) LL-LLK = air-to-air charge air cooler

The values given in this data sheet are for information purposes only and not binding. The information given in the offer is decisive.

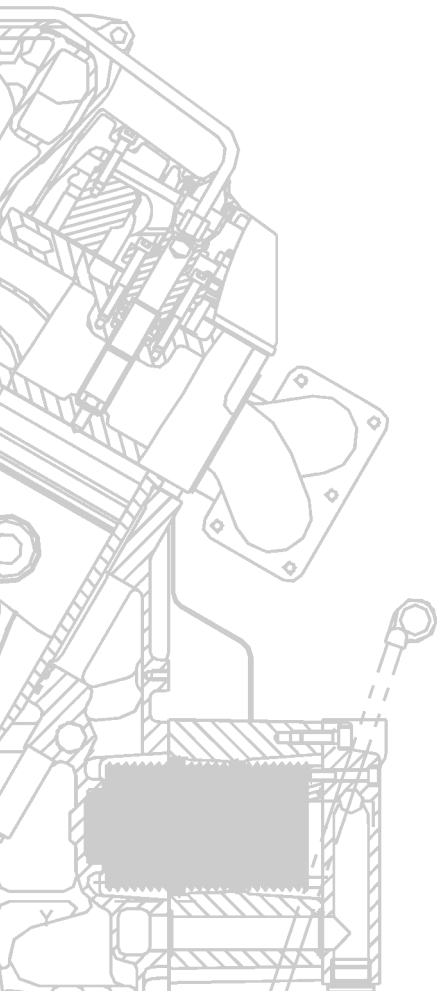

► Dimensions

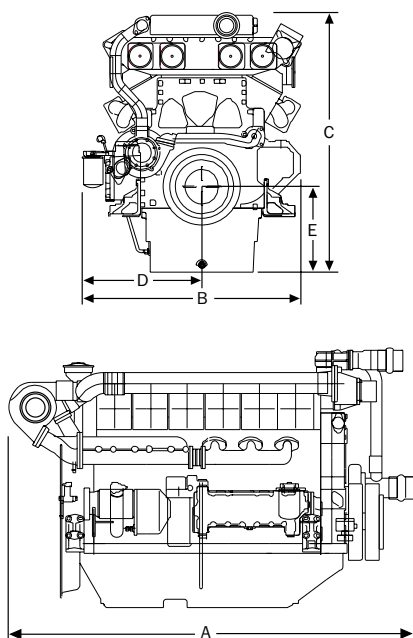

Engine type without cooler		A	B	C	D	E
TBD 616V8	mm	1178	1328	1581	664	400
TBD 616V12	mm	1514	1328	1635	664	400
TBD 616V16	mm	1858	1504	1720	752	400

► Standard specification

- Standard engine:**..... Basic parts
- Cooling system:**..... 1. Fan cooling with air-to-air charge air cooling:
Cooling water pump for engine circuit, cooling water thermostat, flexible connection for cooling water inlet and outlet, cooling water pipes on engine.
2. Fan cooling with air-to-water charge air cooling:
In addition a cooling water circulating pump for charge air cooling circuit.
- Exhaust system:**..... Exhaust manifolds and elbow, two exhaust turbochargers with moulded insulation part and connecting flanges.
- Intake system:**..... Intake manifolds, crankcase breather with return pipe to intake manifold.
- Filters:**..... Dry air cleaner with restriction indicator, fuel and lube oil single filters.
- Governor:**..... Electronic governor.
- Flywheel:**..... Flywheel with 14" connection for V8 and V12, with 18" connection for V16.
- Adapter housing:**..... SAE o housing.
- Engine electrics:**..... Starter motor 24 V, 6.6 kW, alternator 24 V, 55 A, contact maker for coolant overtemperature and lube oil vacuum.
- Miscellaneous:**..... Painting in diamond grey, operation manual, spare parts catalogue.



Knowing it's DEUTZ.

DEUTZ AG

Deutz-Mülheimer Str. 147-149

D-51057 Köln

Telephone: ++ 49 (0) 2 21-8 22-25 10

Fax: ++ 49 (0) 2 21-8 22-25 29

Internet: <http://www.deutz.de>